

## Overview

# Tower-Roller Plus Set-15 Kg

Product number: 37023713

## Options

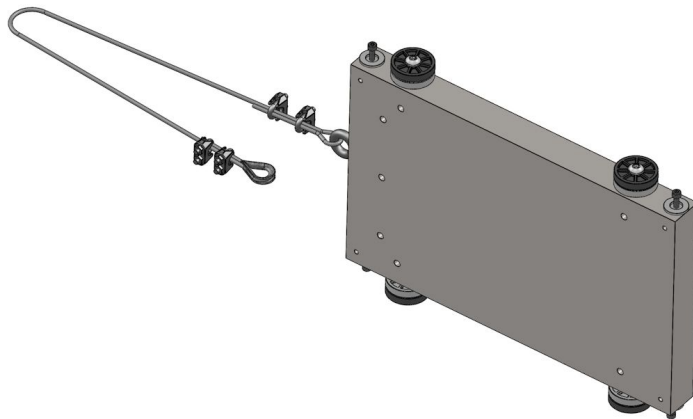

## Weight (kg)

15

25

## Description

The Tower Roller Plus Set is part of our Tower Roller Plus drive system, which features the following properties:

- Drive system for medium and large roller screens, as well as rollable side vents and room partitions.
- Suitable for system lengths up to 120 meters with an extremely narrow installation depth of approximately 80 mm.
- Reduced weight, assembly time, and costs.
- Extremely durable and almost maintenance-free, thanks to the high-strength plastic rollers and the standard anodized aluminum profile.
- Reduced risk of accidents due to completely integrated and covered counterweights and pulleys.
- Integrated cable routing with energy chain.
- Compatible with all common motors (counterweight is adjusted accordingly).

Erstellt am 25.04.2025.

Dieses Dokument stellt kein Angebot da. Es gelten die aktuellen Preise im Online-Shop.

\* Our offers are directed exclusively to companies. We do not conclude contracts with consumers. All prices excl. VAT plus shipping costs and possible delivery charges, if not stated otherwise.